

KR730 Roller Registration Conveyor

Register a wide range of product efficiently and conveniently with the KR730 Roller Registration Conveyor.

The KR730 adjusts quickly and easily to accommodate a wide range of material from small 3" x 3" single sheet up to 15" x 15" books. The unique non-angled infeed and outfeed rollers maintain registration integrity.

The unique design of the KR730 allows you to configure it to match your space requirements. Product can exit right, left or straight through.

The versatility of the KR730 separates it from the competition. Invest in the KR730 and find out how a little versatility can make a big difference in your productivity.



** Guards may have been removed for clarity; Do not operate machine without guards in place.

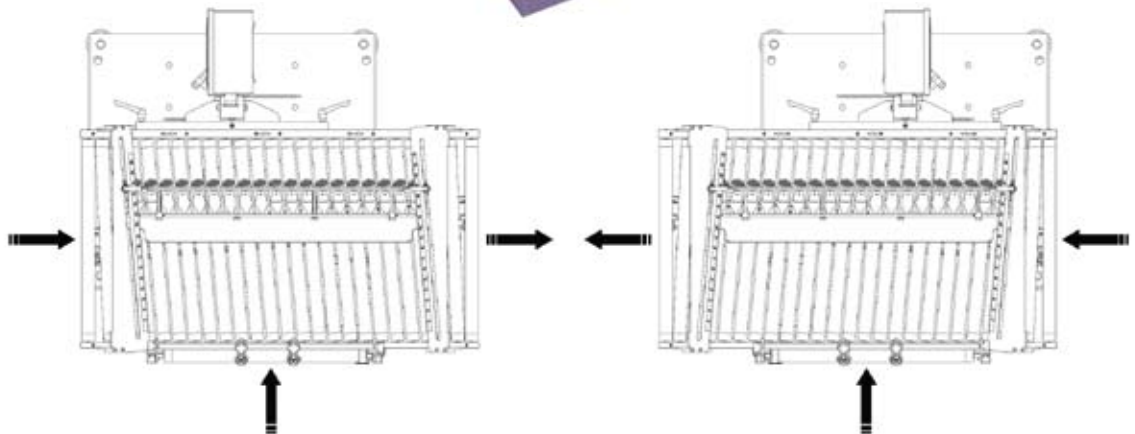

A wide product size range and the ability to deliver product registered inline, to the right or left make the KR730 one of the most versatile roller registration conveyors on the market.



KR730

Roller Registration Conveyor

**General Specifications:

Physical	English	Metric
Length	38.3"	97.2 cm
Width	34.0"	86.4 cm
Height	58.5"	148.6 cm

Electrical Requirements

Voltage	PH	Amp	Hz
120/200 VAC	I	8/4	50/60

Roller Maximum Speed

Maximum	650 fpm (220mpm)
---------	------------------

Product Specifications

	Minimum:	Maximum:
Size	3" x 3" (76.2mm x 76.2mm)	15" x 15" (381mm x 381mm)
Thickness	.004" (.102mm)	.25" (6.4mm)

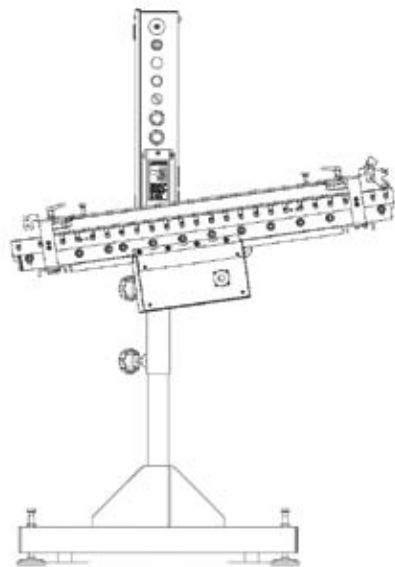

The KR730 conveyor is shown being used as an in-line incline registration conveyor.

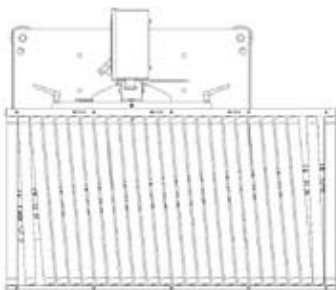

The unique infeed and outfeed rollers are not angled to ensure the product stays registered after leaving the conveyor.



Features & Benefits:

- First angled roller registration table to include non-angled transfer rollers on the infeed and outfeed to ensure the product stays registered after leaving the conveyor.
- Smaller diameter rollers transport large and small product sizes even with large length to width ratios.
- Super fast set-up times with no tools required.
- Accurately control the speed of the in-coming product with the speed-up roller to ensure proper delivery for registration every time.
- Adjustable product transfer pinch rollers help transfer product at critical points and ensure product stays registered.
- Consistently register product in a 90 degree or straight through product flow configuration.
- Easily transport product from up to 10 inches in height difference by using the conveyor as an incline or decline conveyor while registering your product.
- Height adjustments are made quick and easy by the assistance of a powerful gas spring.
- Move easily in place with four swivel casters and optional foot operated floor jacks.
- Durable belt drive system keep things quiet and is easy to maintain with quick belt changes to greatly minimize down time.
- A quiet individually driven cone skid-bar to handle heavy and thin products reliably.
- Two variable high-speed DC motors.
- Control panel is mounted high for maximum visibility and ease of use.
- Up stream "Stop-Out" and down stream "Stop-In" interface.

** Specifications subject to change without notice.